

TFA12TI
TFA15TI
TFA12TIRD37H
TFA15TIRD37H

INTEGRAL
HYDRAULIC
FLANGE
ALIGNMENT
TOOLS



CONTENTS

1. INTRODUCTION
2. TOOL SAFETY
 - 2.1 GENERAL SAFETY
 - 2.2 PERSONNEL COMPETENCY
 - 2.3 DISCLAIMER
 - 2.4 DEFINITION OF TERMS
 - 2.5 HAZARDS
3. TOOL OPERATION
 - 3.1 GENERAL GUIDANCE
 - 3.2 HANDLING
 - 3.3 TOOL INSTALLATION
 - 3.4 ADJUSTMENT LEG
 - 3.5 WING EXTENSION
 - 3.6 CYLINDER ADJUSTMENT SLEEVE
 - 3.7 TOOL CHECKS
 - 3.8 ALIGNMENT
 - 3.9 SECURING THE FLANGE JOINT
4. TOOL MAINTENANCE
 - 4.1 INSPECTION
 - 4.2 CLEANING
 - 4.3 SERVICING
 - 4.4 LUBRICATION PROCEDURE
 - 4.5 STORAGE & TRANSPORTATION
 - 4.6 OPERATING CONDITIONS
 - 4.7 SUB-SEA USAGE
5.
 - 5.1 TOOL CAPABILITIES
 - 5.2 TOOL FUNCTION
 - 5.3 KIT CONTENTS
 - 5.4 DIMENSIONS
6. TROUBLESHOOTING
7. REGULATORY INFORMATION
 - 7.1 REGISTERED HEAD OFFICE
 - 7.2 APPLICABLE PATENT NUMBERS
8. PARTS LISTS & SERVICE KITS

12/02/18

1.

INTRODUCTION

The Equalizer™ range of TFA integral hydraulic flange alignment tools have been developed to assist in the aligning of large flanges on the inside of large pipes, for example those which make up the tower sections of a wind-turbine.

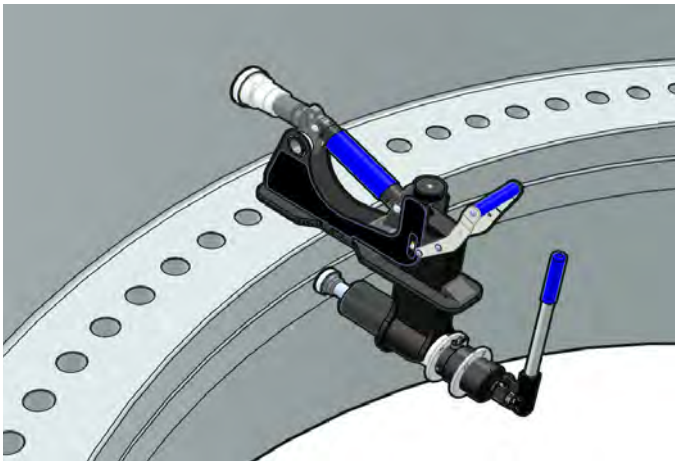

The tools have been designed to cope with the larger loads and dimensions associated with these flange joints while remaining relatively lightweight and user-friendly.

It is essential that the users familiarise themselves with the contents of this manual prior to using the tool.

This manual contains information for the following tools:

- TFA12TI
Integral Hydraulic Flange Alignment Tool
- TFA15TI
Integral Hydraulic Flange Alignment Tool
- TFA12TIRD37H
Integral Hydraulic Flange Alignment Tool
- TFA15TIRD37H
Integral Hydraulic Flange Alignment Tool

2.

TOOL SAFETY

2.1

GENERAL SAFETY

These instructions cover the safe operation and maintenance of THE EQUALIZER RANGE OF **TFA INTEGRAL HYDRAULIC FLANGE ALIGNMENT** tools. The use of any tools should be as part of a broader task-based risk assessment, which should be carried out by the operation supervisor or other competent person.

Failure to comply with the safety information contained within this manual could result in personal injury or equipment damage. Read all instructions, warnings and cautions carefully, and follow all safety precautions.

The safety of the operator, any assisting personnel and the general public is of paramount importance. Always work in accordance with applicable national, local, site & company-wide safety procedures.

2.2

PERSONNEL COMPETENCY

Only personnel deemed competent in the use of mechanical and hydraulic equipment should use these tools.

2.3

DISCLAIMER

Equalizer cannot be held responsible for injury or damage resulting from unsafe product use, lack of maintenance or incorrect product and/or system operation. If in doubt as to the safety precautions and applications, contact Equalizer using the contact details at the back of this manual.

2.4

DEFINITION OF TERMS

A **CAUTION** is used to indicate correct operating or maintenance procedures and practices to prevent damage to, or destruction of equipment or other property.

A **WARNING** indicates a potential danger that requires correct procedures or practices to avoid personal injury.

A **DANGER** is only used when your action or lack of action may cause serious injury or even death.



DO: an illustration showing how the tool should be used.



DON'T: an illustration showing an incorrect way to use a tool.

2.5

HAZARDS



WARNING: ensure all hydraulic components are rated to a safe working pressure of 700 bar (10 000 psi).



WARNING: Do not overload equipment. The risk of hydraulic overloading can be minimised by using the Equalizer Hand Pump, which has a factory-set safety valve preventing the safe working pressure being exceeded.

If alternative hydraulic pumps are used, ensure that there are adequate systems to limit the the working pressure to 700 bar (10 000 psi).



CAUTION: ensure components are protected from external sources of damage, such as excessive heat, flame, moving machine parts, sharp edges and corrosive chemicals.



CAUTION: Take care to avoid sharp bends and kinks in hydraulic hoses. Bends and kinks can cause severe back-up pressure and cause hose failure. Protect hoses from dropped objects; a sharp impact may cause

internal damage to hose wire strands. Protect hoses from crush risks, such as heavy objects or vehicles; crush damage can cause hose failure.



WARNING: Applying pressure to a damaged hose may cause it to rupture.



WARNING: Immediately replace worn or damaged parts. Use only genuine Equalizer parts from approved distributors or service centres. Equalizer parts have been engineered and manufactured to be fit-for-purpose.



DANGER: To minimise risk of personal injury keep hands and feet away from the tool and workpiece during operation.



WARNING: Always wear suitable clothing and Personal Protective Equipment (PPE). Do not handle pressurised hoses; escaping oil under pressure can penetrate the skin, causing serious injury. Seek medical attention immediately if oil penetration is suspected.



WARNING: Only pressurize complete and fully connected hydraulic systems. Do not pressurize systems that contain unconnected couplers.



CAUTION: Do not lift hydraulic equipment by the hoses or couplers. Use only the designated carrying handles.



CAUTION: Lubricate tools as directed in this manual prior to operation. Use only approved lubricants of high quality, following the lubricant manufacturers instructions.

3.

TOOL OPERATION

3.1

GENERAL GUIDANCE

Prior to alignment, an assessment should be carried out to determine the most appropriate positioning of the tool on the flange joint.



The TFA flange alignment tool should always be installed in such a way that the lower flange is closer to the user and the upper flange is further away. The tool is designed to hook into the bolt-hole of the upper flange and push the lower flange into alignment.

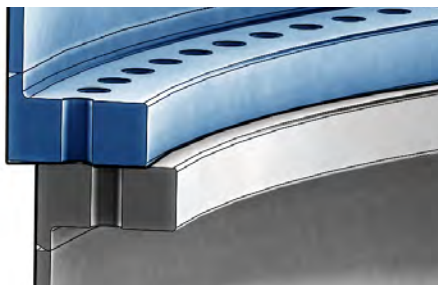

Prior to installation, ensure the Adjustment Leg and Cylinder Adjustment Sleeve are fully retracted. Ensure that the Alignment piston is fully retracted.

3.2

HANDLING

The tool should be lifted and maneuvered using its two handles.

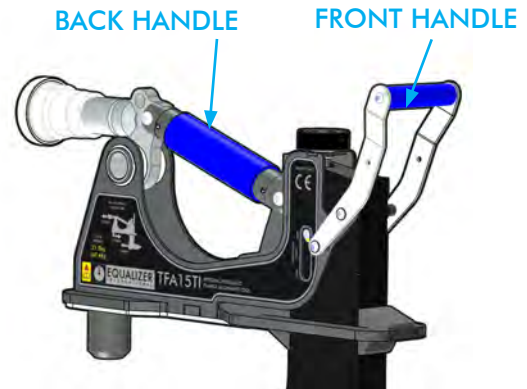

3.3

TOOL INSTALLATION

Position the tool into the bolt-hole ensuring that the hook is fully located into the bolt-hole and the base plate of the tool is sitting flat against the upper flange.

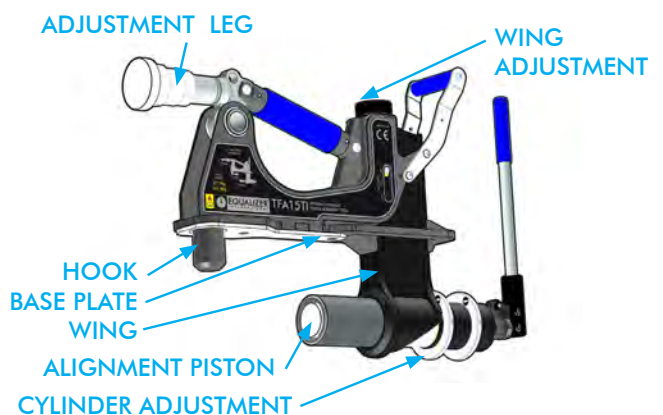
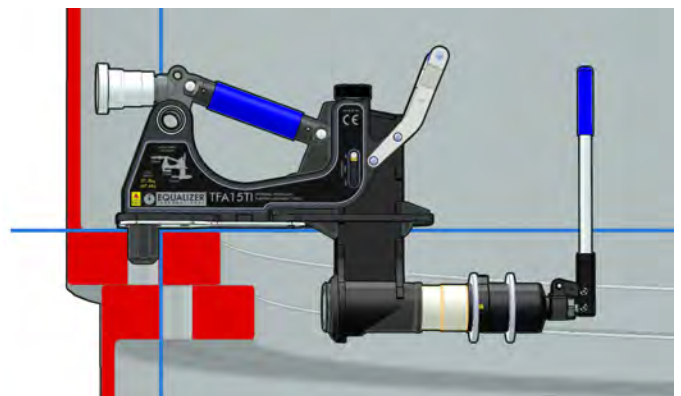

3.4 ADJUSTMENT LEG

Extend the Adjustment Leg by turning the knurled foot clockwise until it contacts the pipe wall. Ensure that the tool is sitting squarely.

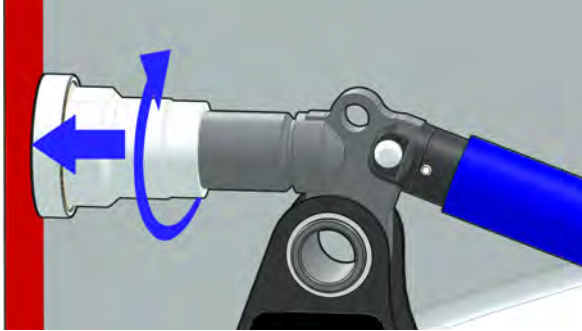

3.5 WING EXTENSION

The Alignment Piston is located on an adjustable wing which can be extended to enable the tool to be used on a variety of flange sizes.

Use the Wing Extension adjustment knob to lower the wing until the foot of the Alignment piston is positioned within the space between the upper and lower faces of the lower flange.

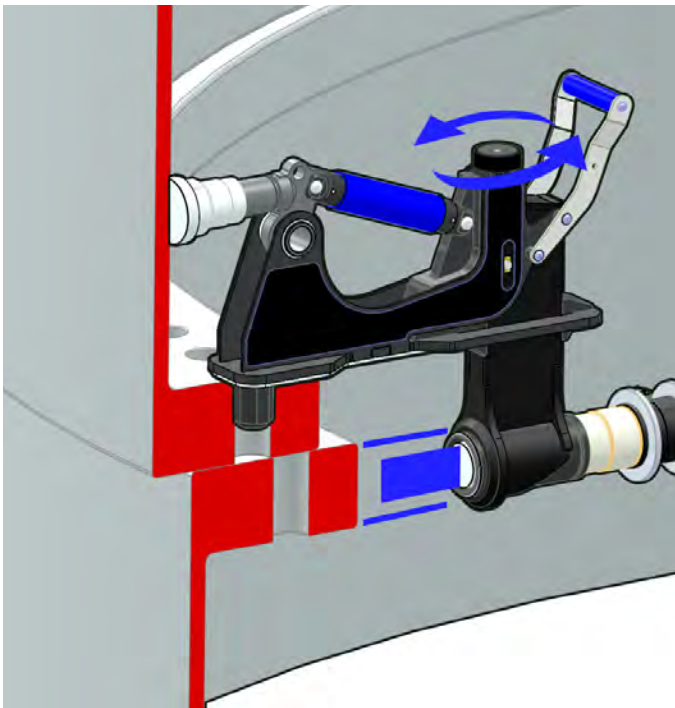

3.6 CYLINDER ADJUSTMENT SLEEVE

The Alignment Piston has a 65 mm stroke. The Cylinder Adjustment Sleeve extends the reach of the tool to fit a variety of flange sizes, without compromising its maximum alignment capacity.

Turn the Cylinder Adjustment Sleeve by the knurled ring until the Alignment Foot is touching the lower flange.

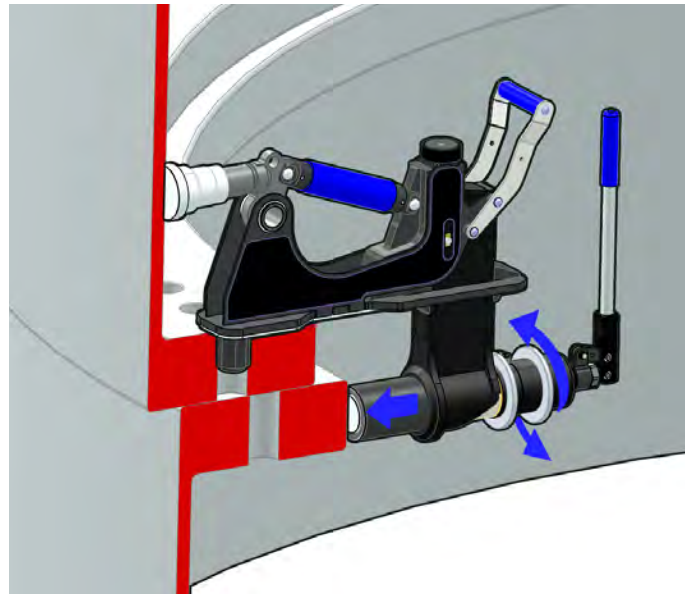

3.7

TOOL CHECKS



Ensure that the tool is sitting square on the flange, that the wing is parallel to the pipe wall and that the Adjustment Leg is adjusted prior to actuating the tool. Actuating the tool when it is not correctly installed could cause injury or equipment damage.

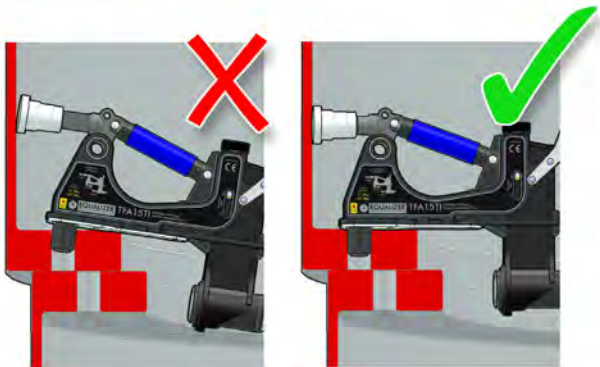
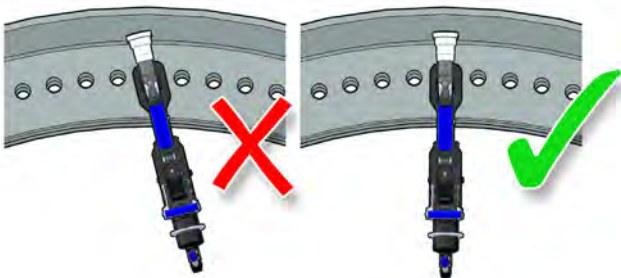
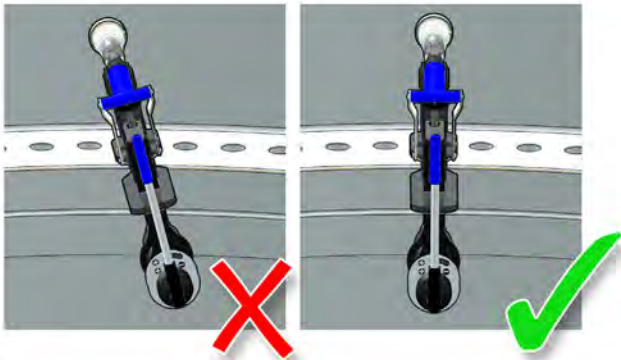

Do not allow fingers, hands or other body parts to come into contact with the flange while actuating the tool. Only hold the tool by its designated handles.

3.8

ALIGNMENT

Refer to section 5.2 for tool actuation instructions.

Actuating the tool will extend the Alignment Piston and align the flanges.

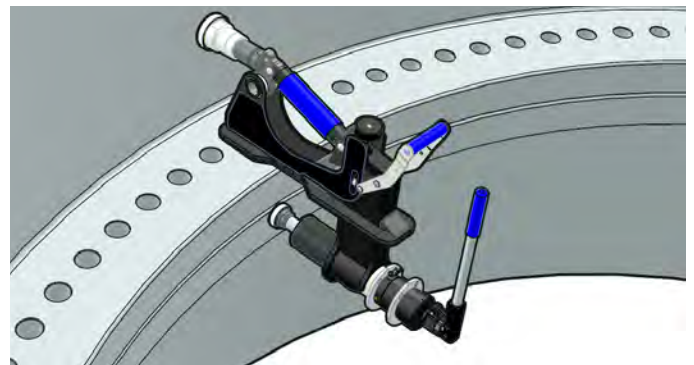
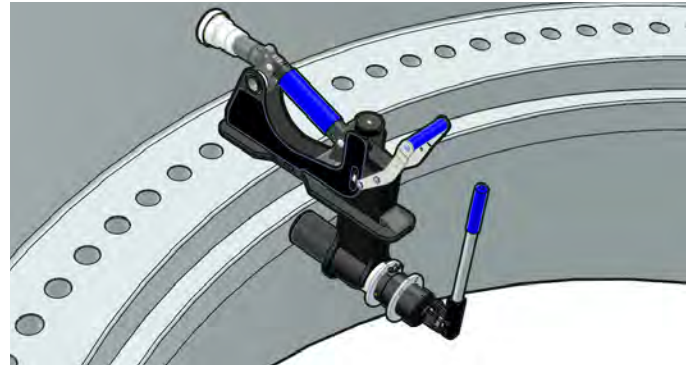

3.9

SECURING THE FLANGE JOINT

After the flange joint has been aligned it can be secured by installing as many bolts as possible into the bolt holes.

It may be necessary to repeat the alignment process several times while working around the flange joint.

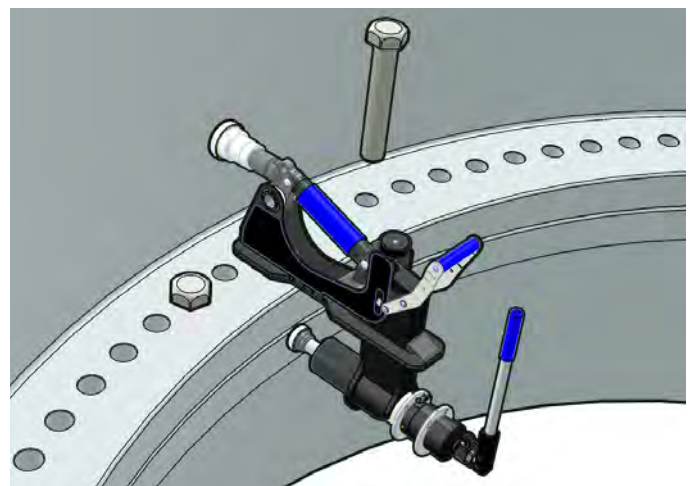

4.

TOOL MAINTENANCE

4.1 INSPECTION

A thorough inspection should be carried out prior to usage, storage or transportation to ensure the completeness and condition of the tool.

Inspection should include:

- visual inspection of the outer parts of the tool, checking for obvious damage, degradation or missing parts
- visual inspection of the Alignment Piston (requiring tool actuation). Damage to the Alignment Piston can be indicative of tool over-load.

Cleaning and servicing should be undertaken as required prior to the tool being used, stored or transported.

4.2 CLEANING

To lightly clean the tool, wipe gently with a damp cloth.

If more thorough cleaning is required (for example following immersion in water) carry out the following cleaning procedure:

- strip the tool down, observing the schematics in section 8
- clean the components using detergent, following the manufacturer's guidelines
- rinse the components to remove traces of detergent
- dry the components thoroughly

Inspect, service and lubricate the tool immediately after the cleaning process.

4.3 SERVICING

Replace missing worn or damaged parts. Use only genuine Equalizer parts from approved distributors or service centres. Equalizer parts have been engineered and manufactured to be fit-for-purpose.

Grease all moving parts by following the Lubrication Procedure prior to usage, storage or transportation.

If topping up or replacing hydraulic oil as part of a service, use only premium quality hydraulic oil of the grade 15 cSt.

4.4 LUBRICATION PROCEDURE

Apply grease following cleaning and servicing, prior to usage, storage or transportation. Never assemble and leave a tool without following the greasing procedure as degradation or damage may occur.

Use only high pressure molybdenum disulphide grease.

Apply grease liberally to the following areas:

- the Adjustment Leg thread
- the Wing Extension thread
- the Cylinder Adjustment thread

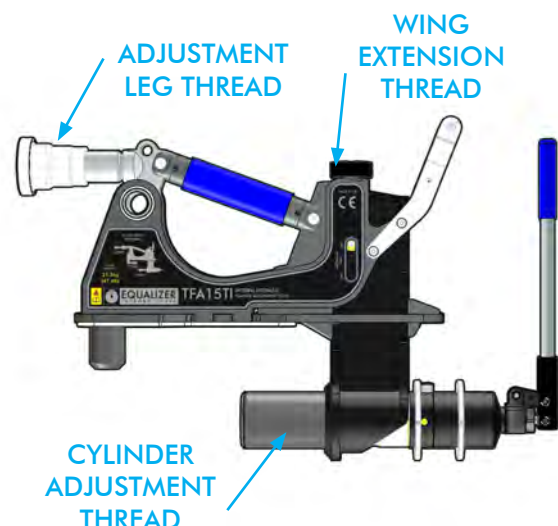

4.5

STORAGE & TRANSPORTATION

Equalizer tools should be stored in a cool dry place. Tools should always be cleaned, serviced and lubricated prior to storage. Ensure that tools are stored in their designated packing cases.

4.6

OPERATING CONDITIONS

HYDRAULIC TOOLS:

Minimum Flange Contact Temperature: -30 °C (-22 °F)

Maximum Flange Contact Temperature: 70 °C (158 °F)

4.7

SUB-SEA USAGE

Using TFA integral hydraulic tools Sub-Sea

The TFA integral hydraulic tools are actuated by means of a single-acting spring-return hydraulic cylinder and can be used sub-sea providing the following actions are taken:

- The pump release valve is fully opened and remains open until the tool has descended to the working depth. This will allow the pressure to equalise.
- The tool is actuated via the hand pump by a diver.
- Upon completion of works the release valve is left in the fully-open position until the tool has ascended to the surface.
- The tool and pump are stripped-down, cleaned and lubricated immediately to minimise corrosion.

5.

The TFA integral hydraulic flange alignment tools use an integral hydraulic cylinder to advance the alignment foot and align the flanges.

5.1 TOOL CAPABILITIES

ALIGNMENT FORCE

The following table shows the alignment force (F) through the alignment foot when the maximum integral pump pressure is applied. Reaction forces (R_1 & R_2) vary depending on the extension of the wing.

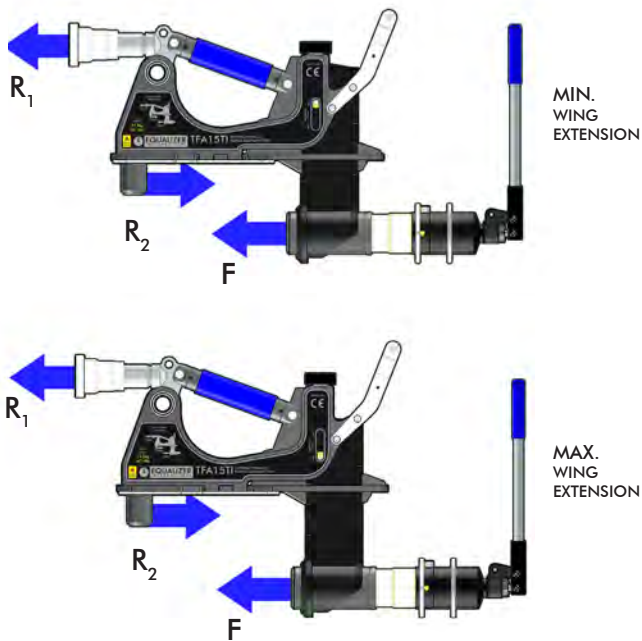

FORCE			TFA12TI	TFA15TI	TFA12TI RD37H	TFA15TI RD37H
F	ALIGNMENT FORCE	MIN	12 T	15 T	12 T	15 T
		MAX	12 T	15 T	12 T	15 T
R_1	REACTION FORCE 1	MIN	10 T	9 T	7 T	6.5 T
		MAX	12 T	12 T	8.7 T	8.7 T
R_2	REACTION FORCE 2	MIN	22 T	24 T	19 T	21.5 T
		MAX	24 T	27 T	20.7 T	23.7 T

RANGE OF APPLICATION

	DIMENSION		TFA12TI	TFA15TI	TFA12TI RD37H	TFA15TI RD37H
B	Bolt Hole Diameter		45 mm	45 mm	37 mm	37 mm
M	Misalignment	MIN	0 mm	0 mm	0 mm	0 mm
		MAX	65 mm	65 mm	65 mm	65 mm
R	Rise	MIN	150 mm	150 mm	150 mm	150 mm
		MAX	250 mm	250 mm	250 mm	250 mm
D	Pipe Leg Drop	MIN	83 mm	83 mm	53 mm	53 mm
		MAX	123 mm	123 mm	93 mm	93 mm
W	Wing Reach	MIN	160 mm	120 mm	160 mm	120 mm
		MAX	203 mm	160 mm	203 mm	160 mm
H	Reaction Spacing	MIN	200 mm	200 mm	275 mm	275 mm
		MAX	200 mm	200 mm	275 mm	275 mm

MINIMUM EXTENSION

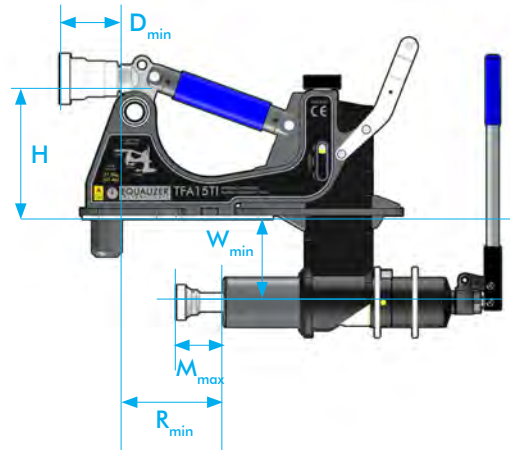

MAXIMUM EXTENSION

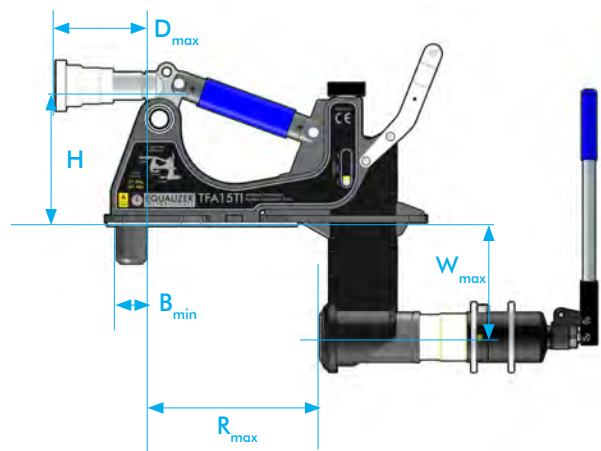

5.2 TOOL FUNCTION

HYDRAULIC TOOL OPERATION

Prior to operation, ensure the air-vent in the integral hand pump is not obstructed. Any obstruction in the air-vent can cause a vacuum in the system which can limit the cylinder's travel.

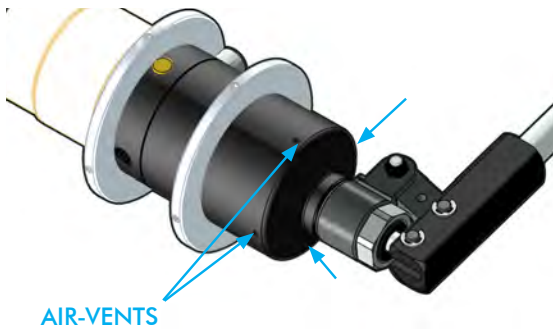

The TFA integral hydraulic tools use a hydraulic cylinder to advance the Alignment Piston and align the flanges. The hydraulic pressure is applied using the integrated hand pump, enabling accurate control of the force applied.

The integral hand pump has a control lever which allows the user to select advance (+) or retract (-).



ACTUATING THE TOOL

Follow the Tool Operation instructions (see Section 3), using the following instructions to actuate the tool.

When advance (+) is selected, pumping the handle will advance the Alignment Piston.



RETRACTING THE TOOL

Selecting retract (-) will depressurise the cylinder and cause it to retract under the force of its internal spring. The handle does not need to be pumped to retract the tool.

5.3 KIT CONTENTS



5.4 DIMENSIONS

	TOOL WEIGHT	BOX DIMENSIONS	X	Y	Z
TFA12TI	20.5 kg (45.2 lb)	585 mm (23.0") 900 mm (35.4") 160 mm (11.8")	104 mm (4.10")	470 mm (18.5")	635 mm (25.0")
TFA15TI	20 kg (44.1 lb)	585 mm (23.0") 900 mm (35.4") 160 mm (11.8")	104 mm (4.10")	430 mm (16.9")	635 mm (25.0")
TFA12TI RD37H	22.3 kg (49.2 lb)	585 mm (23.0") 900 mm (35.4") 160 mm (11.8")	104 mm (4.10")	521 mm (20.5")	636 mm (25.0")
TFA15TI RD37H	21.7 kg (47.8 lb)	585 mm (23.0") 900 mm (35.4") 160 mm (11.8")	104 mm (4.10")	482 mm (19.0")	636 mm (25.0")

TFA12TI STANDARD KIT	1 x TFA12TI Tool 1 x Instruction Manual 1 x Hard Case Product Code: TFA12TISTD
TFA15TI STANDARD KIT	1 x TFA15TI Tool 1 x Instruction Manual 1 x Hard Case Product Code: TFA15TISTD
TFA12TIRD37H STANDARD KIT	1 x TFA12TIRD37H Tool 1 x Instruction Manual 1 x Hard Case Product Code: TFA12TIRD37HSTD
TFA15TIRD37H STANDARD KIT	1 x TFA15TIRD37H Tool 1 x Instruction Manual 1 x Hard Case Product Code: TFA15TIRD37HSTD

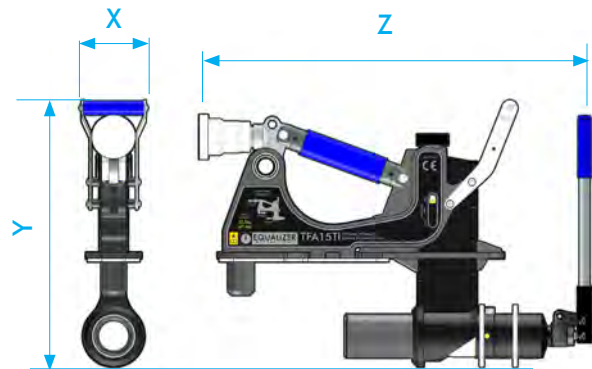

6.

TROUBLESHOOTING

THE ALIGNMENT PISTON ADVANCES SOME OF THE WAY AND THEN STOPS PROGRESSING

POSSIBLE CAUSE:

- The air-vent is obstructed by dirt or debris.
- The tool has reached its maximum load.

RECOMMENDED ACTION:

- Carefully unblock the air-vent using a small blunt object.

THE ALIGNMENT PISTON DOESN'T MOVE

POSSIBLE CAUSE:

- There is an air-lock within the hydraulic system.

RECOMMENDED ACTION:

- Select Retract (-) and prime pump to circulate oil around the system.

POSSIBLE CAUSE:

- Insufficient oil in the hydraulic system.

RECOMMENDED ACTION:

- Refer to an approved Equalizer distributor for further instruction.

POSSIBLE CAUSE:

- Retract (-) is selected.

RECOMMENDED ACTION:

- Select Advance (+) and pump the handle.

POSSIBLE CAUSE:

- Air has accumulated around pump inlet when used upside down.

RECOMMENDED ACTION:

- Inspect the tool for oil leaks on the reservoir, possibly indicative of a perished bladder. Refer to an approved Equalizer distributor for repair.

THE ALIGNMENT PISTON MOVES AS INTENDED, BUT DOESN'T SEEM TO BE ACHIEVING FULL PRESSURE WHEN UNDER LOAD

POSSIBLE CAUSE:

- Intermediate valve not seating / relief valve leaking.

RECOMMENDED ACTION:

- Refer to an approved Equalizer distributor for further instruction.

HYDRAULIC PRESSURE SLOWLY DIMINISHES AND THE PUMP HANDLE RISES

POSSIBLE CAUSE:

- The outlet check valve is leaking.

RECOMMENDED ACTION:

- Refer to an approved Equalizer distributor for further instruction.

HYDRAULIC PRESSURE SLOWLY DIMINISHES AND THE PUMP HANDLE DOES NOT RISE

POSSIBLE CAUSE:

- The release valve is leaking.

RECOMMENDED ACTION:

- Refer to an approved Equalizer distributor for further instructions.

POSSIBLE CAUSE:

- The piston seal is leaking.

RECOMMENDED ACTION:

- Inspect the tool for oil leaks, possibly indicative of a perished seal or loose blanking plug. Refer to an approved Equalizer distributor for further instructions.

TOOL ACTUATION FEELS SOFT AND UNRESPONSIVE

POSSIBLE CAUSE:

- There is air in the hydraulic system.

RECOMMENDED ACTION:

- Refer to an approved Equalizer distributor for further instruction.

7.

REGULATORY INFORMATION

7.1

REGISTERED HEAD OFFICE

EQUALIZER INTERNATIONAL LTD.
Equalizer House
Claymore Drive
Aberdeen
Scotland
AB23 8GD

7.2

APPLICABLE PATENT NUMBERS

The following list of Patents and Design Registrations are applicable to EQUALIZER INTERNATIONAL LTD TFA tools:

REGISTERED PATENTS

- 5832582
- AU690191
- NO319697
- 6327763
- 318535
- 0916051B
- 0024229878
- 84481
- 95727
- 44142
- 45155

8.

PARTS LISTS & SERVICE KITS

TI PARTS LIST

270000-01 REV.01

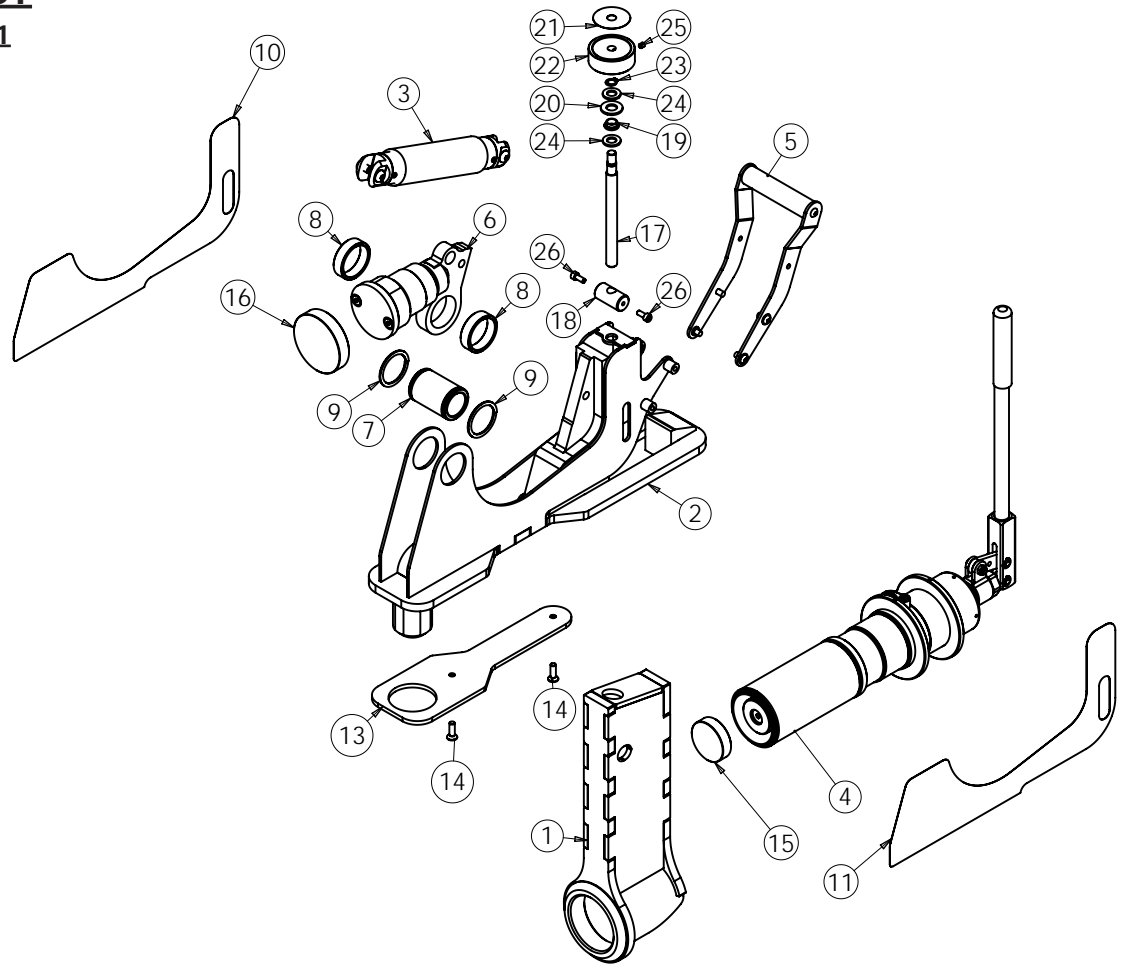

ITEM NO.	DESCRIPTION	PART NO.			
		TFA12TI	TFA15TI	TFA12TIRD37H	TFA15TIRD37H
1	WING ARM_WELDED ASSEMBLY	1210100-01	270100-01	1210100-01	270100-01
2	BODY ASSEMBLY - WELDED	270200-01	270200-01	270200-01	270200-01
3	STRUT ASSEMBLY	270300-01	270300-01	270300-01	270300-01
4	CYLINDER ASSEMBLY	270500-01	270500-01	270500-01	270500-01
5	HANDLE ASSEMBLY	271300-01	271300-01	271300-01	271300-01
6	ADJUSTABLE LEG ASS	270400-01	270400-01	1690200-01	1690200-01
7	ADJUSTMENT LEG FIXING SHAFT	270900-01	270900-01	270900-01	270900-01
8	SIDE SPACER BUSH	272000-01	272000-01	272000-01	272000-01
9	SPIRAL CLIP	270800-01	270800-01	270800-01	270800-01
10	RHS STICKER	1700002-01	070393-01	1680005-01	1690002-01
11	LHS STICKER	1700001-01	070392-01	1680004-01	1690001-01
13	PROTECTION PAD	KIT 271400-01	KIT 271400-01	KIT 271400-01	KIT 271400-01
14	M6 CSK HEX SCREW				
15	FOOT CAP FLANGE				
16	FOOT CAP TOWER				
17	ADJUSTMENT ROD	KIT 271500-01	KIT 271500-01	KIT 271500-01	KIT 271500-01
18	ADJUSTER BOSS				
19	ADJUSTMENT BUSH				
20	ADJUSTMENT BUSH WASHER				
21	WING ADJUST DECAL				
22	RELEASE KNOB				
23	10MM EXTERNAL CIRCLIP				
24	WASHER 10mm ID				
25	M5 SCKT SET SCREW				
26	M5x12mm SCKT HEAD CPSCREW				

TI CYLINDER ASSEMBLY PARTS LIST

270500-01 REV.01

ITEM NO.	PART NO	DESCRIPTION	QTY/ASS
1	840300-01	H.CYLINDER & PUMP TI ASSEMBLY	1
2	270600-01	CYLINDER FOOT ASSEMBLY	1
3	270701-01	CYLINDER ADJUSTING RING	2
4	270501-01	TI CYLINDER SLEEVE	1
5	KIT 271900-01	SPIRAL RETAINING RING	2
6		M6 SCKT SET SCREW	1
7		M5 SCKT SET SCREW	4

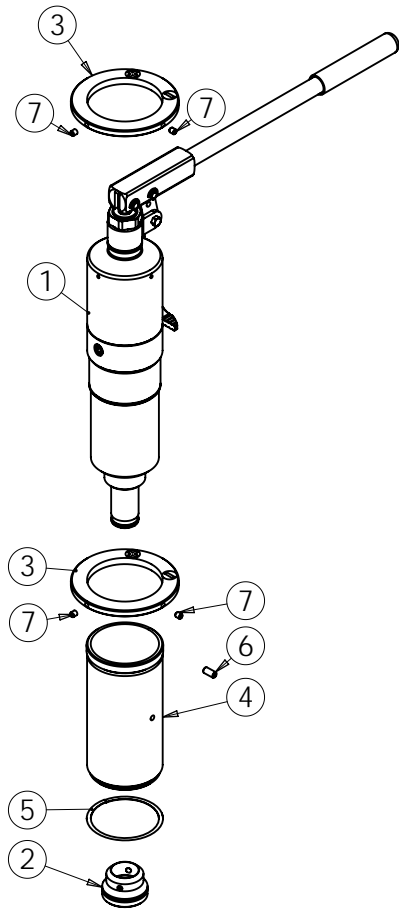

TI CYLINDER PARTS LIST

840300-01 REV.02

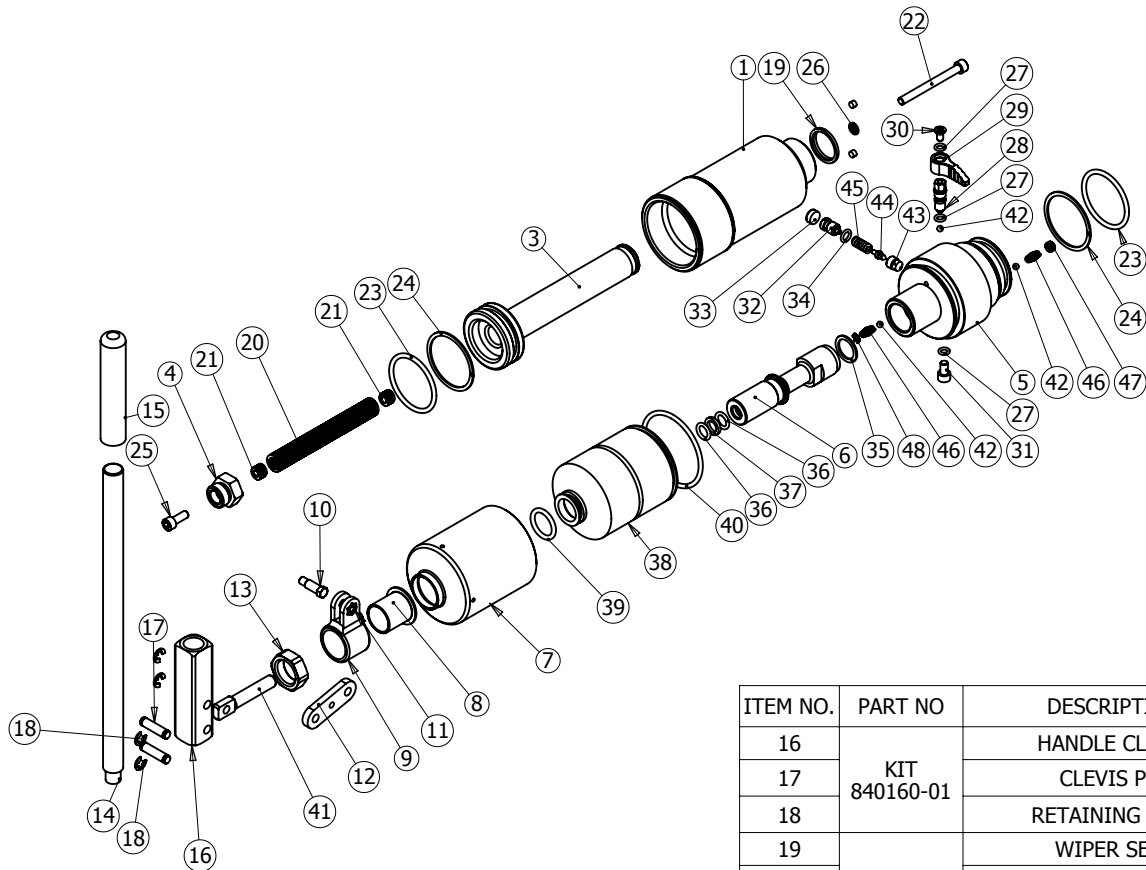

ITEM NO.	PART NO	DESCRIPTION	QTY.
1	830301-01	CYLINDER BODY	1
2	830310-01	CYL VENT PLUG	2
3	830302-01	PISTON	1
4	840100-01	NUT	1
5	840301-01	CYLINDER BASE	1
6	376901-01	PUMP PISTON HOUSING	1
7	840302-01	BLADDER HOUSING	1
8	372401-01	PISTON HOUSING CAP	1
9	372501-01	SWIVEL CLEVIS	1
10	373201-01	CLEVIS SCREW	1
11	373301-01	ANTI-LOOSEN NUT	1
12	373101-01	LINK CONNECTOR	1
13	372601-01	RETAINING NUT	1
14	373401-01	HANDLE ROD	1
15	306502-01	HANDLE GRIP	1

ITEM NO.	PART NO	DESCRIPTION	QTY.
16		HANDLE CLEVIS	1
17	KIT 840160-01	CLEVIS PIN	2
18		RETAINING RING	4
19		WIPER SEAL	1
20		TENSION DIE SPRING	1
21		SPRING LOCK	2
22	KIT 840110-01	M6 CAPSCREW	1
23		O-RING	2
24		BACK-UP RING	2
25		SCREW	1
26		M6 GASKET SEAL	1
27		O-RING	3
28		RELIEF VALVE SCREW	1
29		RELIEF VALVE KNOB	1
30		FIXING SCREW	1
31		OIL FILL SCREW	1
32		OVERLOAD COVER SCREW	1
33		CAP	1
34	KIT 840120-01	O-RING	1
35		WASHER	1
36		O-RING	2
37		BACK UP RING	1
38		RESERVOIR BLADDER	1
39		O-RING	1
40		O-RING	1
41		PUMP PISTON ROD	1
42		STEEL BALL	1
43		STEEL BALL	2
44		CONE SEAT	1
45		CONE	1
46	KIT 375020-01	LONG SEPARATOR SPRING	1
47		SPRING	2
48		SCREW	1
49		SPRING LOCK	1

STRUT ASSEMBLY PARTS LIST

270300-01 REV.01

ITEM NO.	PART NO	DESCRIPTION	QTY/ASS
1	270301-09	STRUT TUBE	1
2	270302-09	CLEVIS	2
3	KIT 271600-01	M8 BUTTON HEX SCREW	4
4		FOAM GRIP - 34MM X 135MM	1
5		6MM ROLL PIN	2

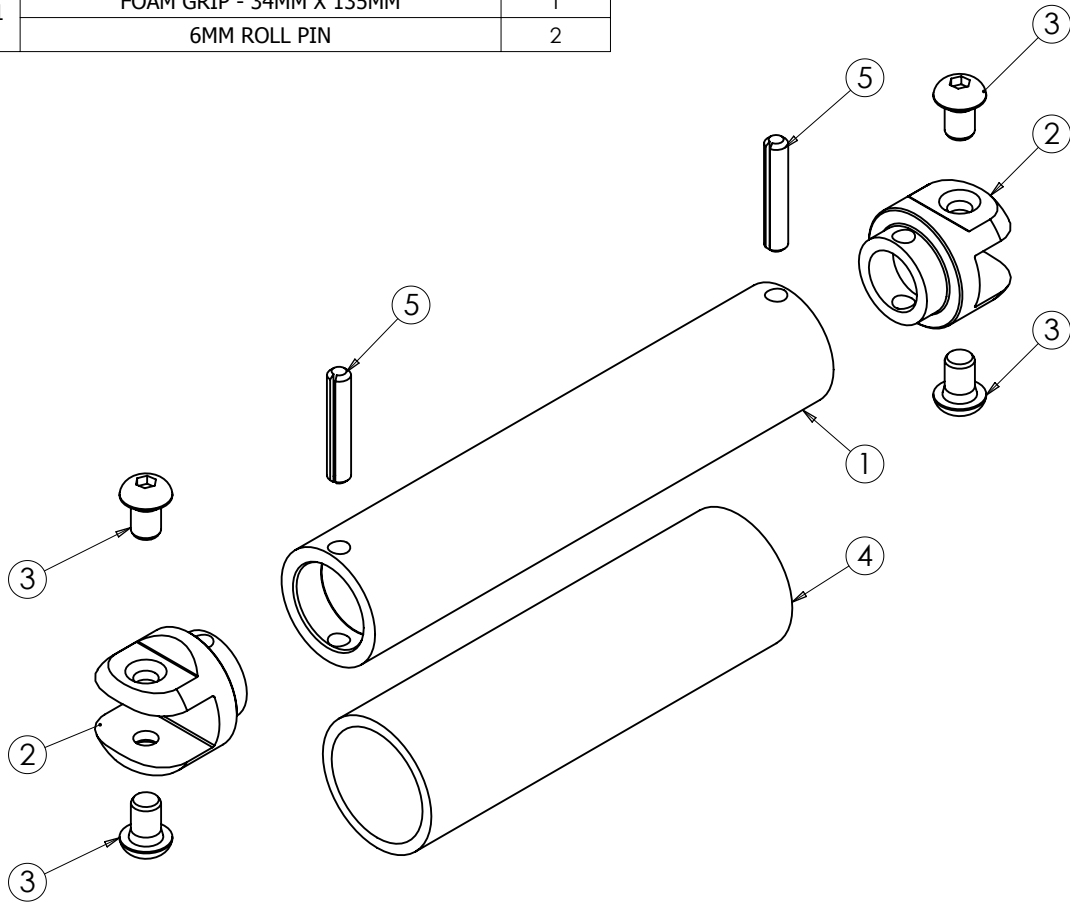

SAFETY BOND ASSEMBLY PARTS LIST

270800-01 REV.01

ITEM NO.	PART NO	DESCRIPTION	QTY/ASS
1	270800-01	SAFETY BOND ASSEMBLY	1

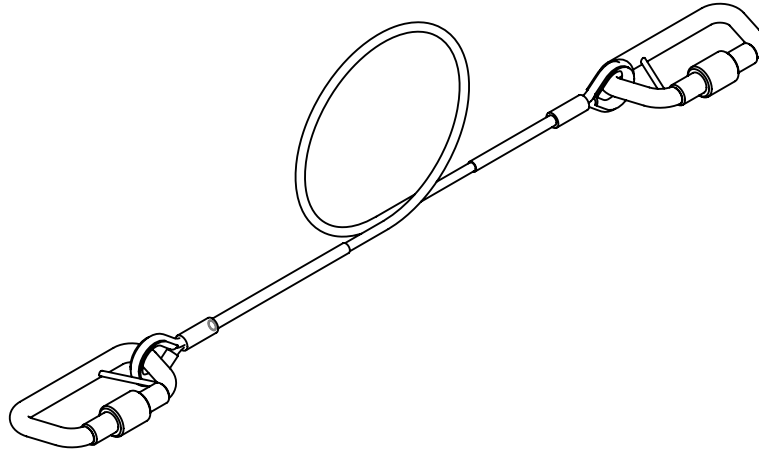

HANDLE ASSEMBLY PARTS LIST

271300-01 REV.01

ITEM NO.	PART NO	DESCRIPTION	QTY/ASS
1	501301-01	HANDLE BAR	1
2	501101-01	HANDLE LEFT	1
3	501201-01	HANDLE RIGHT	1
4	KIT 271800-01	BLUE HANDLE SLEEVE	1
5		WASHER (0.8MM)	6
6		SCREW FOR HANDLE	6
7		SPACER	2

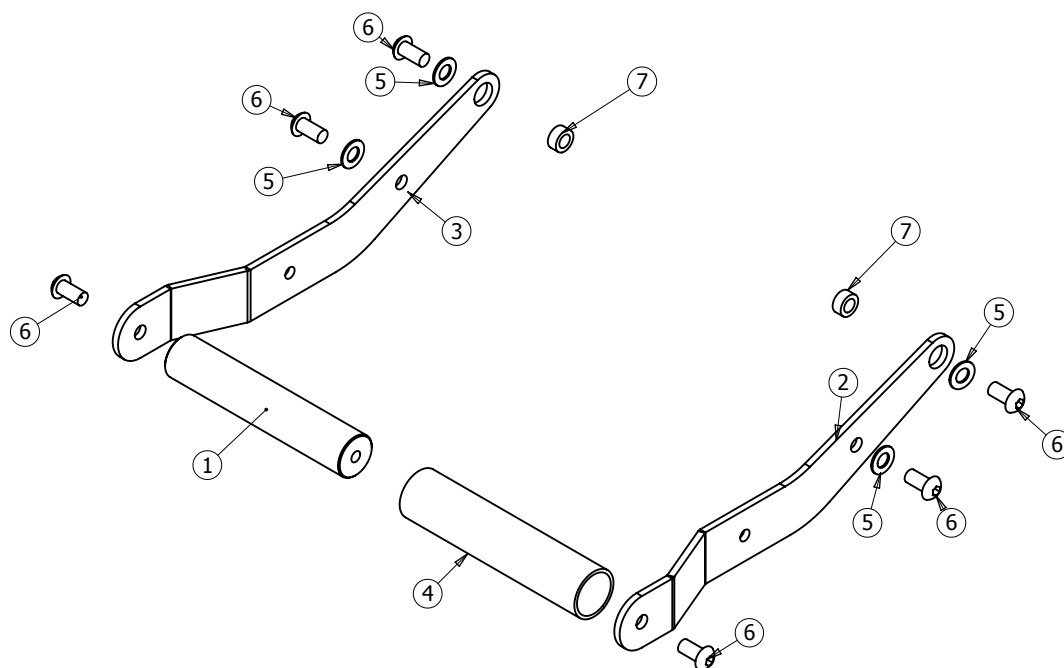

ADJUSTMENT LEG ASSEMBLY PARTS LIST

270400-01 REV.01

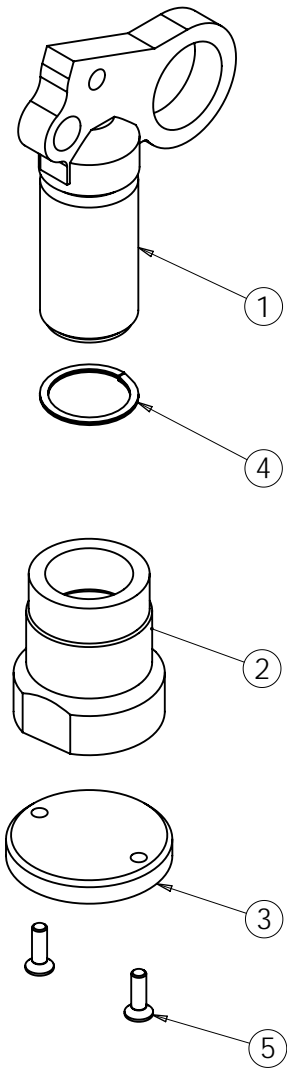

ITEM NO.	DESCRIPTION	QTY/ ASS	PART NO.			
			TFA12TI	TFA15TI	TFA12TIRD37H	TFA15TIRD37H
1	CLEVIS WELDED ASSEMBLY	1	270401-01	270401-01	1690201-01	1690201-01
2	ADJUSTMENT FOOT	1	270402-01	270402-01	270402-01	270402-01
3	ADJUSTMENT FOOT PAD	1	KIT 271700-01	KIT 271700-01	KIT 271700-01	KIT 271700-01
4	SPIRAL CLIP	1				
5	M6 CSK HEX SCREW	2				

PROTECTIVE PAD SERVICE KIT

271400-01 REV.01

ITEM NO.	DESCRIPTION	QTY/ASS
1	M6 CSK HEX SCREW	2
2	FOOT CAP TOWER	1
3	FOOT CAP FLANGE	1
4	PROTECTION PAD	1

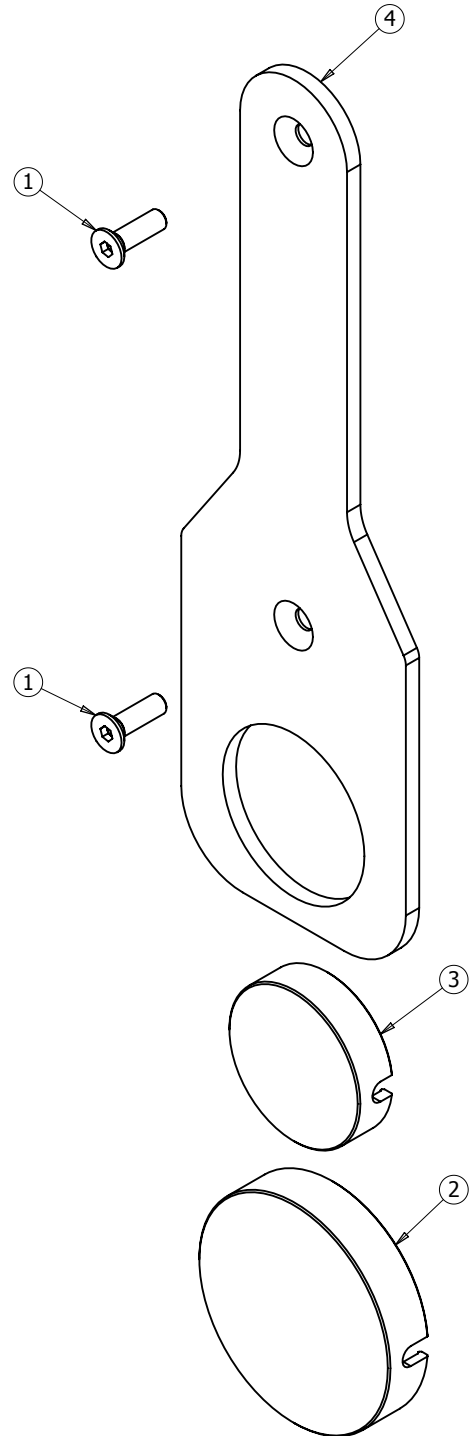

WING ADJUSTMENT SERVICE KIT

271500-01 REV.01

ITEM NO.	DESCRIPTION	QTY/ASS
1	ADJUSTMENT ROD	1
2	ADJUSTER BOSS	1
3	ADJUSTMENT BUSH	1
4	ADJUSTMENT BUSH WASHER	1
5	WING ADJUST DECAL_TFA15TI	1
6	RELEASE KNOB	1
7	10MM EXTERNAL CIRCLIP	1
8	WASHER 10mm ID	2
9	M5 SCKT SET SCREW	4
10	M5x12mm SCKT HEAD CPSCREW	2

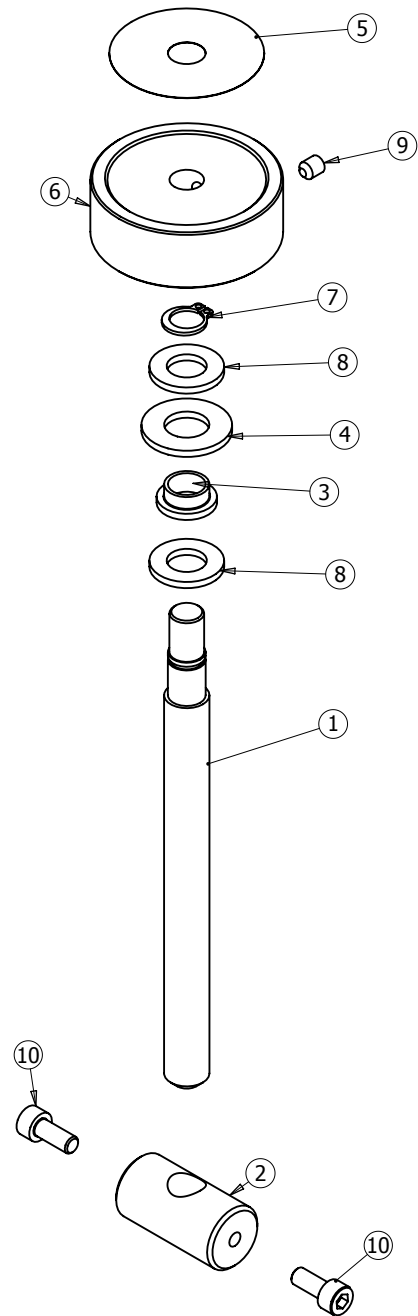

CLEVIS SERVICE KIT

840160-01 REV.01

ITEM NO.	DESCRIPTION	QTY
1	HANDLE CLEVIS	1
2	CLEVIS PIN	2
3	RETAINING RING	4

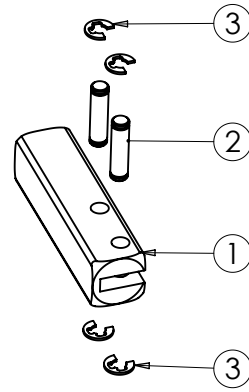

INTEGRAL MANIFOLD SERVICE KIT

375020-01 REV.01

ITEM NO.	DESCRIPTION	QTY.
1	STEEL BALL	2
2	CONE SEAT	1
3	CONE	1
4	LONG SEPARATOR SPRING	1
5	SPRING	2
6	SCREW	1
7	SPRING LOCK	1

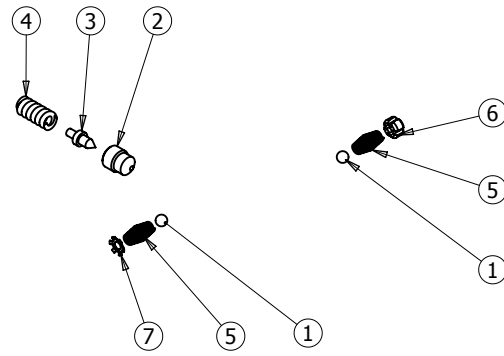

INTEGRAL BLADDER SERVICE KIT

840120-01 REV.02

ITEM NO.	DESCRIPTION	QTY.
1	STEEL BALL	1
2	O-RING	3
3	RELIEF VALVE SCREW	1
4	RELIEF VALVE KNOB	1
5	FIXING SCREW	1
6	OIL FILL SCREW	1
7	OVERLOAD COVER SCREW	1
8	CAP	1
9	O-RING	1
10	WASHER	1
11	O-RING	2
12	BACK UP RING	1
13	O-RING	1
14	PUMP PISTON ROD	1
15	RESERVOIR BLADDER	1
16	O-RING	1

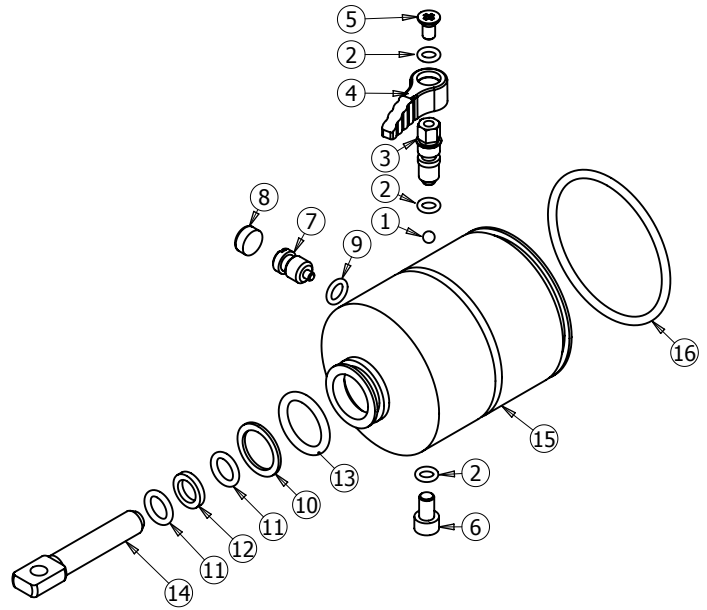

CYLINDER SERVICE KIT

840110-01 REV.02

ITEM NO.	DESCRIPTION	QTY.
1	WIPER SEAL	1
2	TENSION DIE SPRING	1
3	SPRING LOCK	2
4	M6 CAPSCREW	1
5	O-RING	2
6	BACK-UP RING	2
7	SCREW	1
8	M6 GASKET SEAL	1

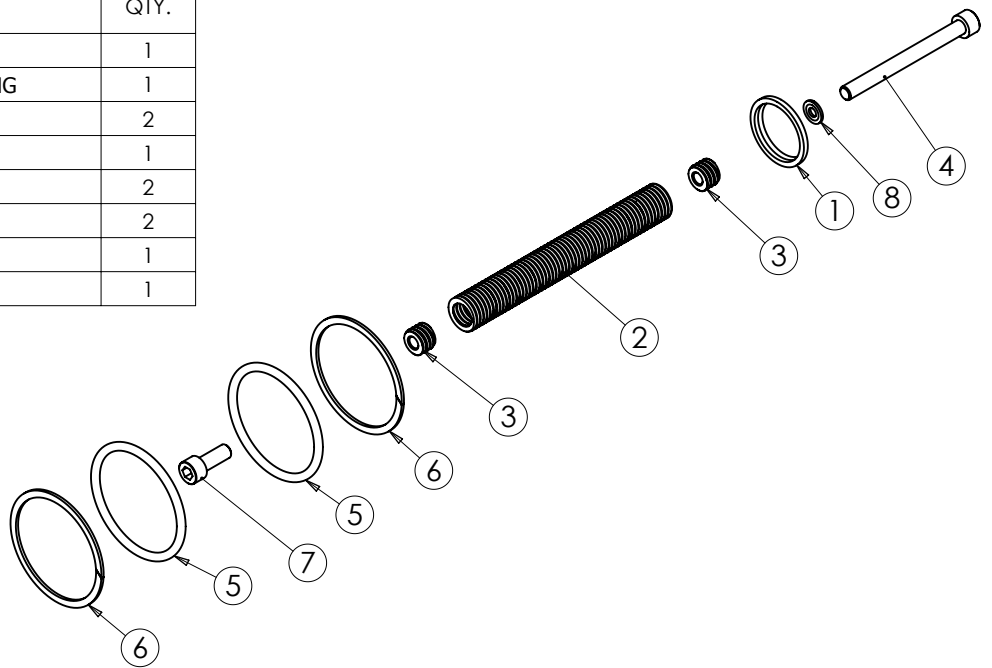



EQUALIZER INTERNATIONAL LTD.

**Head Office
Equalizer House
Claymore Drive
Aberdeen
Scotland
UK**

**AB23 8GD
t: +44 (0) 1224 701970
f: +44 (0) 1224 823791**

**Houston Office
1330 Yale Street
Houston TX 77008
USA**

t: +1 (713) 927-1840

www.equalizerinternational.com